

(19) World Intellectual Property Organization  
International Bureau



(43) International Publication Date  
3 January 2002 (03.01.2002)

PCT

(10) International Publication Number  
WO 02/01119 A1

- (51) International Patent Classification<sup>7</sup>: F24J 2/52, 2/42
- (21) International Application Number: PCT/AU01/00742
- (22) International Filing Date: 22 June 2001 (22.06.2001)
- (25) Filing Language: English
- (26) Publication Language: English
- (30) Priority Data:  
PQ 8375 23 June 2000 (23.06.2000) AU
- (71) Applicant and
- (72) Inventor: BRAUN, Richard [GB/AU]; Suite 10, 172  
Macquarie Street, St Lucia, QLD 4067 (AU).
- (74) Agent: PULLEN, Kevin; PO Box 241, Landsborough,  
QLD 4550 (AU).

CZ, DE, DK, DM, DZ, EC, EE, ES, FI, GB, GD, GE, GH, GM, HR, HU, ID, IL, IN, IS, JP, KE, KG, KP, KR, KZ, LC, LK, LR, LS, LT, LU, LV, MA, MD, MG, MK, MN, MW, MX, MZ, NO, NZ, PL, PT, RO, RU, SD, SE, SG, SI, SK, SL, TJ, TM, TR, TT, TZ, UA, UG, US, UZ, VN, YU, ZA, ZW.

(84) Designated States (regional): ARIPO patent (GH, GM, KE, LS, MW, MZ, SD, SL, SZ, TZ, UG, ZW), Eurasian patent (AM, AZ, BY, KG, KZ, MD, RU, TJ, TM), European patent (AT, BE, CH, CY, DE, DK, ES, FI, FR, GB, GR, IE, IT, LU, MC, NL, PT, SE, TR), OAPI patent (BF, BJ, CF, CG, CI, CM, GA, GN, GW, ML, MR, NE, SN, TD, TG).

Published:  
— with international search report

For two-letter codes and other abbreviations, refer to the "Guidance Notes on Codes and Abbreviations" appearing at the beginning of each regular issue of the PCT Gazette.

- (81) Designated States (national): AE, AG, AL, AM, AT, AU, AZ, BA, BB, BG, BR, BY, BZ, CA, CH, CN, CO, CR, CU,



(54) Title: A MOUNTING

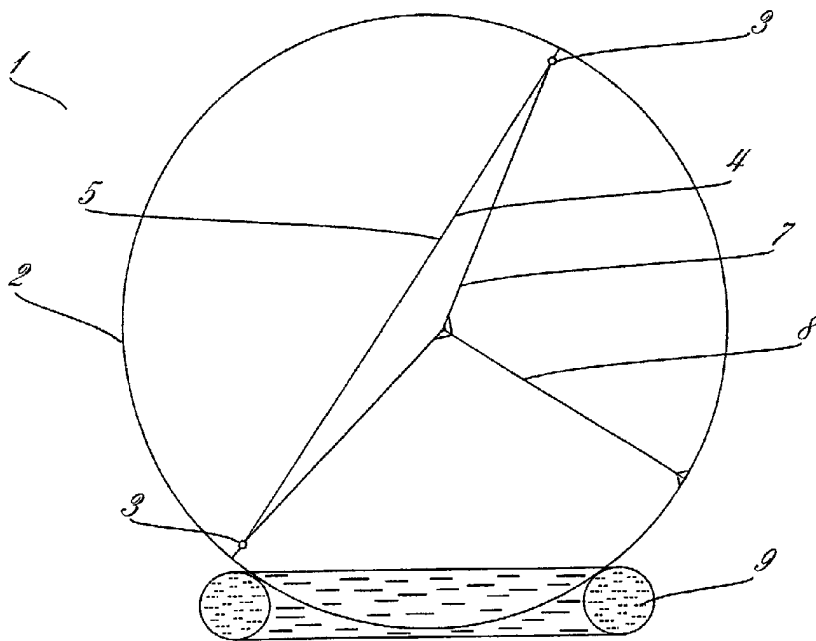

(57) Abstract: A mounting (1) comprises a transparent spherical shell (2), which holds a reflective mirror (4) for collection and concentration of radiation flux. A second membrane (7) is affixed to maintain a pressure differential across the two approximate hemi-spheres separate by the mirror (4). A quantity of water (13) is contained within the shell (2) acting as ballast. The lower portion of the shell (2) rests on a toroid (9), which is affixed to a base (10). Both the toroid and the vessel created by the inside surface of the toroid (9) and base (10) is filled with water (11,12). The shell (2) is buoyantly supported within the vessel by the water (12,13) while being restrained within the boundaries of the toroid (9) and base (10) but free for rotational movement as required to track the sun.

WO 02/01119 A1



















































































